



# ADVANCE ADAPTERS INC.

P.O. Box 247, 4320 Aerotech Center Way  
Paso Robles, CA 93447

Telephone: (800) 350-2223 Fax: (805) 238-4201

## P/N: 50-6304

Old Part No: 711063-LS  
PAGE 1 OF 3

Page Rev. Date: 03-13-01

## GM TH350 AUTOMATIC TO JEEP DANA 300 TRANSFER CASE

### KIT CONSISTS OF:

No.	Qty	Part No.	Description
1.	1	51-6300	CASTING (Ref: 711163) (Assembled by AA)
2.	1	52-6302	SPUD SHAFT (Ref: 711363) (Assembled by AA)
3.	1 Pack	714201	BOLTPACK(50-6300)
4.	1	716308	BEARING (#6209) (Assembled by AA)
5.	1	716450	SNAP RING (Assembled by AA)
6.	1	716456	SNAP RING (T/A #N5000-334) (Assembled by AA)
7.	1	716511	"O" RING
8.	1	716517	GASKET
9.	6	723711	STUD BOLT 3/8"-16X2" LG.

### OPTIONAL ITEMS:

Qty	Part No.	Description
1	716021	CROSSMBR. MOUNT



**SPECIAL NOTE:** The components packaged in this kit have been assembled and machined for specific type of conversions. Modifications to any of the components will void any possible warranty or return privileges. If you do not fully understand modifications or changes that will be required to complete your conversion, we strongly recommend that you contact our sales department for more information. This instruction sheet is only to be used for the assembly of Advance Adapter components. We recommend that a service manual pertaining to your vehicle be obtained for specific torque values, wiring diagrams and other related equipment. These manuals are normally available at automotive dealerships and parts stores.

# ADVANCE ADAPTERS INC.

P.O. Box 247, 4320 Aerotech Center Way  
Paso Robles, CA 93447

Telephone: (800) 350-2223 Fax: (805) 238-4201

**P/N: 50-6304**

Old Part No: 711063-LS  
PAGE 2 OF 3

Page Rev. Date: 03-13-01

## GM TH350 AUTOMATIC TO JEEP DANA 300 TRANSFER CASE

### GM TH350 3 SPEED AUTOMATIC

The General Motors TH350 has a case length of 21-1/2", 13 bolts holding the oil pan in position, and is available in two different engine to transmission bolt patterns. The case is available with a Chevy bolt pattern that has the top two holes 8-1/4" apart, or a Buick bolt pattern that has the top two holes 7" apart. The rear side of the transmission case should have a square bolt pattern that uses 4 bolts. There are several various lengths of output shafts that these transmissions have been furnished with and you must make sure the proper shaft has been installed into the transmission for use with our transfer case kit. We standardize our kits on the GM 4WD output shafts that were used in vehicles 1973-79. All TH350 output shafts will have 27 splines. The speedometer gear is normally located in the tailhousing, but when adapting it to the transfer case, the location will change to the backside of the transfer case. The rear transmission support is located in the main case just forward of the tailhousing connection. This can be used for supporting the crossmember on some installations, but most of our kits provide support on the new adapter housing.

When installing the new transfer case adapter, make sure that the coupler and the output shaft do not bottom out. We have found on occasion that a transmission output shaft may be slightly longer than what we have allowed for; and when coupling into our new spud shaft, we find a small amount of interference. The adapter housing and spud shaft must be assembled to the back of the transmission without interference. **DO NOT FORCE THE NEW TAILHOUSING ONTO THE TRANSMISSION.** If assistance is needed, please feel free to call the number listed above.

When assembling the adapter housing to the transmission case, we have provided you with a new square-type "O" ring seal to prevent fluid leakage. This seal is a stock GM item that is used on all installations. We have also provided a gasket for the Dana 300 to adapter surface. We also recommend a small amount of silicone be used on both surfaces. Loctite should be used on all fasteners.

All installations will require the use of a transmission cooler. The cooler can be either installed in the radiator or a remote location is acceptable. The transmission shift control can either be a Hurst floor mounted type shifter or sometimes the existing column shift can be modified on certain applications.

### INSTALLATION:

1. This kit comes pre-assembled with the bearing, snap rings, and spud shaft installed in the casting. The bearing and spud shaft are a press fit. The spud shaft is pressed to the bearing and the snap ring installed to retain the spud shaft properly. The bearing and spud shaft assembly are also a press fit into the adapter housing. The bearing and spud shaft are pressed into the casting. This assembly is retained with the provided snap ring.
2. Install the o-ring on the casting and use a small amount of silicone to provide a good seal. Bolt the adapter assembly to the TH350 transmission.
3. Using a thin film of silicone on both sides of the transfer case gasket, install the transfer case and gasket to the adapter assembly. The studs in the Dana 300 should locate the transfer case in the proper rotation, and the Dana 300 front alignment retainer should properly index the transfer case.
4. The Advance Adapters crossmember mount will bolt to the bottom of the adapter casting. Mark and drill new holes in the skid plate to secure the transmission assembly to the skid plate.
5. Make sure all fasteners are secured and Loctite is used.

**SPECIAL NOTE:** The components packaged in this kit have been assembled and machined for specific type of conversions. Modifications to any of the components will void any possible warranty or return privileges. If you do not fully understand modifications or changes that will be required to complete your conversion, we strongly recommend that you contact our sales department for more information. This instruction sheet is only to be used for the assembly of Advance Adapter components. We recommend that a service manual pertaining to your vehicle be obtained for specific torque values, wiring diagrams and other related equipment. These manuals are normally available at automotive dealerships and parts stores.

# ADVANCE ADAPTERS INC.

P.O. Box 247, 4320 Aerotech Center Way  
Paso Robles, CA 93447

Telephone: (800) 350-2223 Fax: (805) 238-4201

## P/N: 50-6304

Old Part No: 711063-LS  
PAGE 3 OF 3

Page Rev. Date: 08-23-00

## GM TH350 AUTOMATIC TO JEEP DANA 300 TRANSFER CASE

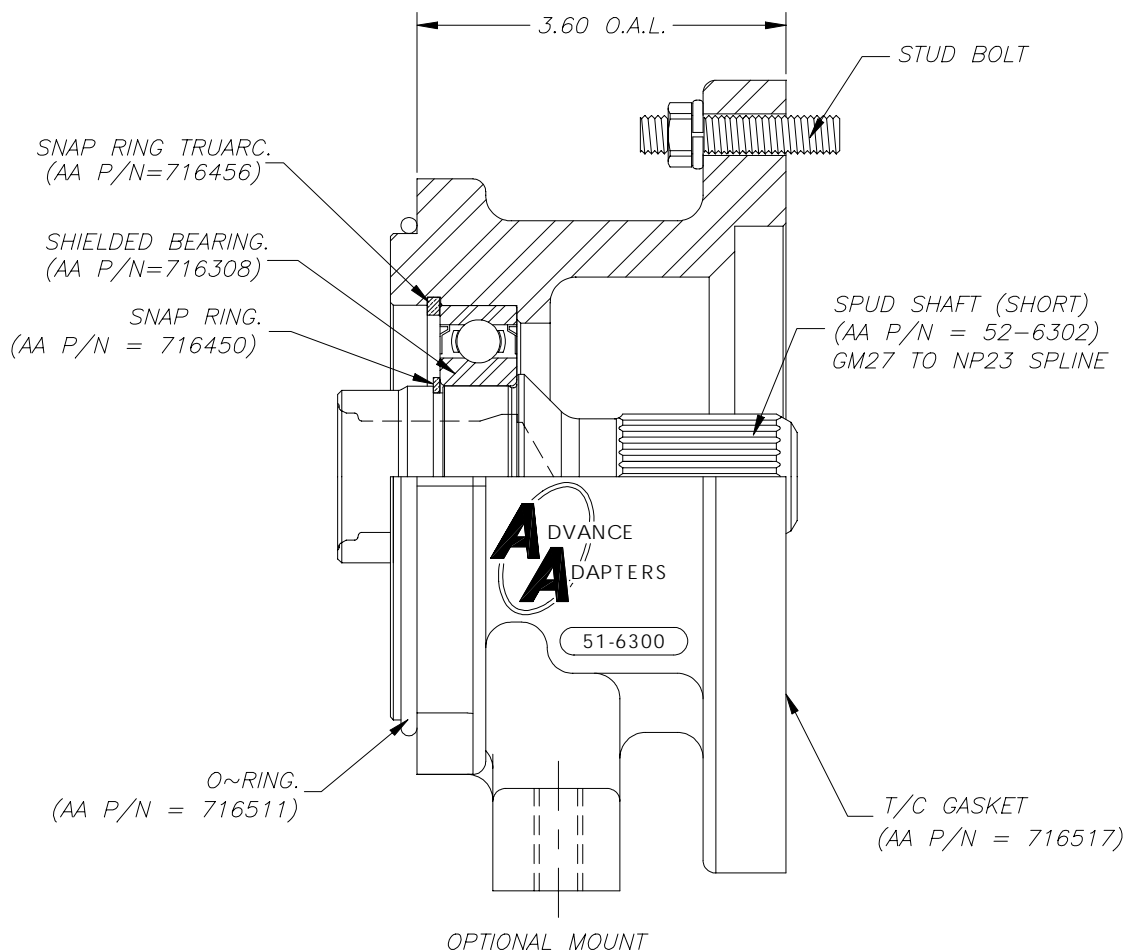

**SPECIAL NOTE:** The components packaged in this kit have been assembled and machined for specific type of conversions. Modifications to any of the components will void any possible warranty or return privileges. If you do not fully understand modifications or changes that will be required to complete your conversion, we strongly recommend that you contact our sales department for more information. This instruction sheet is only to be used for the assembly of Advance Adapter components. We recommend that a service manual pertaining to your vehicle be obtained for specific torque values, wiring diagrams and other related equipment. These manuals are normally available at automotive dealerships and parts stores.