

Installation for Cadillac CTS-V Coupe PN 140754BC



These instructions have been written to help you with the installation of your Borla Performance Exhaust System. Please read this document completely before beginning the installation of your system.

Please compare the parts in the box with the bill of materials provided to assure that you have all the parts necessary for this installation.

To ensure this part number fits your specific model year, please visit our website for the latest model year listings at www.BORLA.com.

Thank you for purchasing a Borla Performance Cat-Back™ Exhaust System.

Borla Performance Cat-Back™ Exhaust System (PN 140754BC) is designed for the Cadillac CTS-V equipped with a 6.2L supercharged engine, automatic transmission.

Borla Performance Industries recommends that an exhaust shop or professional after market parts installer perform the installation of this system. However, if you decide to perform the installation on your own it is recommended that two people are used. This installation should not be performed by one person due to the risk of injury. Ensure the installers use all under car safety precautions including eye protection.

Please take time to read and understand the following...

By installing your Borla Performance exhaust system, you indicate that you have read this document and you agree with the terms stated below. It is the responsibility of the purchaser to follow all installation instruction guidelines and safety procedures supplied with your Borla Performance Exhaust System.

Borla Performance Industries assumes no responsibility for damages occurring from misuse, abuse, improper installation, improper operation, lack of responsible care, or all previously stated reasons resulting from incompatibility with other manufacturer's products and/or systems.

Included with your Borla Performance exhaust system is a warranty card. Please read it carefully before you begin any work on your vehicle. If you should have any questions regarding our warranty policy, installation, or any other matter pertaining to your new Borla Performance Exhaust System, please give us a call at the number provided on the warranty card.

Minimum Required Tool List:

TOOLS:

1. 3/8" drive ratchet
2. 3/8" drive extension 3"
3. 15mm socket
4. 13mm socket
5. 10mm socket
6. 10mm wrench
7. Pry bar

SHOP SUPPLIES:

1. Spray lubricant

Borla Performance Cat-back™ Bill of Materials

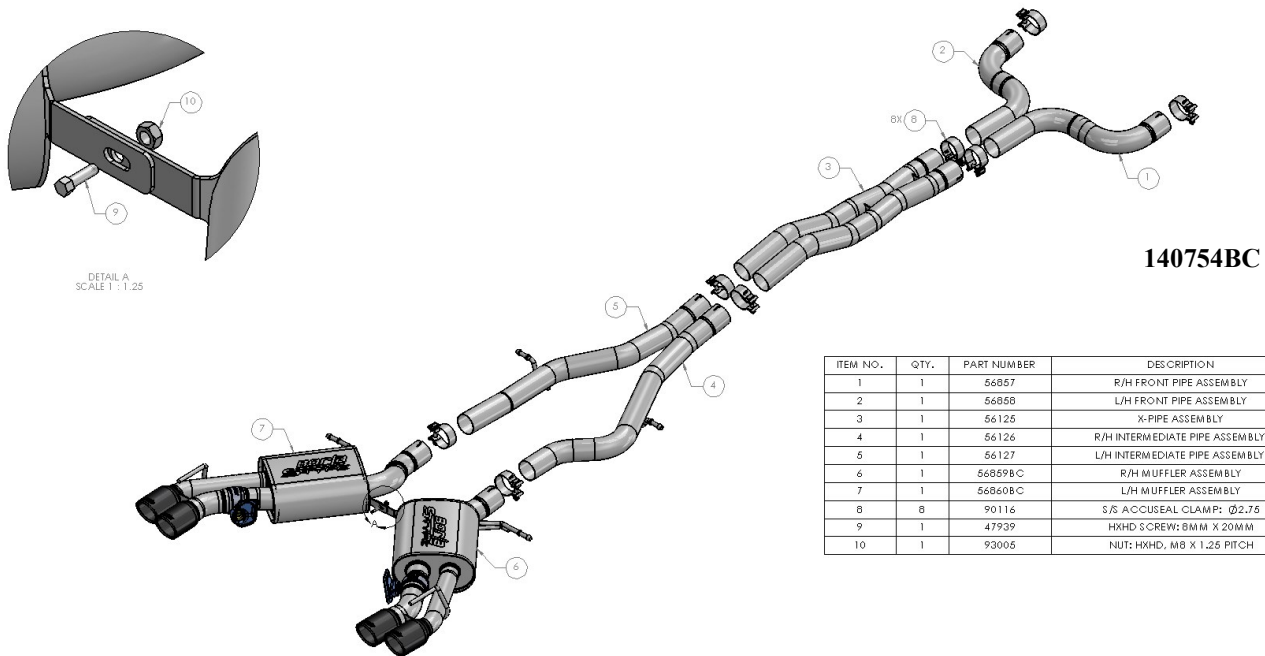

ITEM NO.	QTY.	PART NUMBER	DESCRIPTION
1	1	56857	R/H FRONT PIPE ASSEMBLY
2	1	56858	L/H FRONT PIPE ASSEMBLY
3	1	56125	X-PIPE ASSEMBLY
4	1	56126	R/H INTERMEDIATE PIPE ASSEMBLY
5	1	56127	L/H INTERMEDIATE PIPE ASSEMBLY
6	1	56859B-C	R/H MUFFLER ASSEMBLY
7	1	56860B-C	L/H MUFFLER ASSEMBLY
8	8	90116	3/8" ACCUSEAL CLAMP: Ø2.75
9	1	47939	HXHD SCREW: 8MM X 20MM
10	1	93005	NUT: HXHD, M8 X 1.25 PITCH

Caution!!! *Never* work on a hot exhaust system. Serious injury in the form of burns can result if the vehicle has been in use and the exhaust system is hot, allow vehicle to cool for at least 1 hour. Always wear eye protection when working under any vehicle.

Note: It is our recommendation that you use a hoist or hydraulic lift to facilitate the installation of your new Borla Performance Exhaust System.

Taking all under car safety precautions, lift the vehicle using a hoist or hydraulic lift. Once this has been done, you may begin the removal of your old exhaust system from your vehicle.

Note: Before removing the original exhaust system from your vehicle, please compare the parts you have received with the bill of materials provided on the previous page to assure that you have all the parts necessary for the installation of your new Borla Performance Exhaust System.

Note: With a used vehicle, we suggest a penetrating spray lubricant be applied liberally to all exhaust fasteners and allowing a significant period of time for the chemical to lubricate the threads before attempting to disassemble.

Original Exhaust System Removal

1. Lubricate all exhaust hangers, rubber isolators, bolts and nuts.
2. Measure 3.25" from behind the L/H downstream catalytic converter. Make a cut using a reciprocating saw with a metal-cutting blade. (See fig. 1)
3. Measure 5.25" from behind the passenger-side downstream catalytic converter. Make a cut using a reciprocating saw with a metal-cutting blade. (See fig. 2)
4. Loosen crossmember bolts and remove crossmember. Keep hardware and component for reinstallation. (See fig. 3)
5. Remove L/H and R/H tailpipe rubber isolator brackets and fasteners. Keep hardware and components for reinstallation. (See fig. 4)

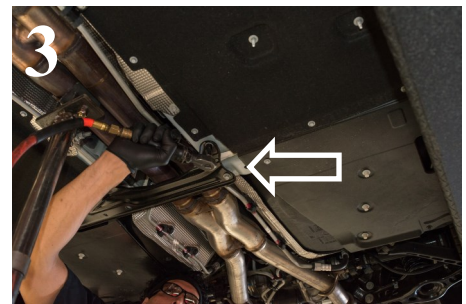

WARNING: Use extreme caution during installation. Torque all fasteners according to manufacturer's torque values and tightening sequence. **DO NOT** use air impact tools to tighten fasteners on Borla Performance Exhaust Systems. Use of such tools may result in bent flanges or gasket contact

NOTE: When you first start your vehicle after the installation of your new Borla Performance Exhaust System, there may be some smoke and fumes coming from the system. This is a protective oil based coating used in the manufacturing of mandrel bent performance exhaust tubing. This is not a problem and will disappear within a very short period of time after the exhaust has reached normal operating temperatures.

Caution!!! *Never* work on a hot exhaust system. Serious injury in the form of burns can result if the vehicle has been in use and the exhaust system is hot, allow vehicle to cool for at least 1 hour. Always wear eye protection when working under any vehicle.

Note: It is our recommendation that you use a hoist or hydraulic lift to facilitate the installation of your new Borla Performance Exhaust System.

Taking all under car safety precautions, lift the vehicle using a hoist or hydraulic lift. Once this has been done, you may begin the removal of your old exhaust system from your vehicle.

Note: Before removing the original exhaust system from your vehicle, please compare the parts you have received with the bill of materials provided on the previous page to assure that you have all the parts necessary for the installation of your new Borla Performance Exhaust System.

Note: With a used vehicle, we suggest a penetrating spray lubricant be applied liberally to all exhaust fasteners and allowing a significant period of time for the chemical to lubricate the threads before attempting to disassemble.

Original Exhaust System Removal Cont'd

6. Exhaust hanger bracket removed. (See fig. 5)
7. Remove L/H and R/H stock exhaust hangers (intermediate pipes and muffler assembly) from L/H and R/H rubber isolators. (See fig. 6)
8. Disconnect wire harnesses from L/H and R/H exhaust valve actuators.
9. Using an additional person, remove the exhaust system from the vehicle.
10. OE exhaust system removed.
11. Remove valve actuators from original exhaust system. (See fig. 8)

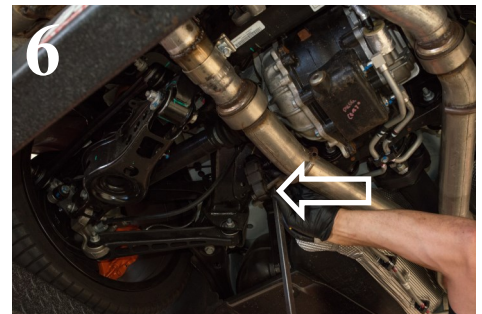

WARNING: Use extreme caution during installation. Torque all fasteners according to manufacturer's torque values and tightening sequence. **DO NOT** use air impact tools to tighten fasteners on Borla Performance Exhaust Systems. Use of such tools may result in bent flanges or gasket contact

NOTE: When you first start your vehicle after the installation of your new Borla Performance Exhaust System, there may be some smoke and fumes coming from the system. This is a protective oil based coating used in the manufacturing of mandrel bent performance exhaust tubing. This is not a problem and will disappear within a very short period of time after the exhaust has reached normal operating temperatures.

Borla Performance Cat-Back™ Exhaust System Installation

1. With the Borla system off of the vehicle, transfer the **L/H and R/H valve actuators** from the OE system to **Borla exhaust valves**. (See fig. 9)
2. Slide band clamps (do on tighten) over **Borla S-pipes**.
3. Referencing the page-2 drawing for orientation, insert the expanded end of the L/H and R/H front **Borla S-pipes** over cut points on OE exhaust. (See fig. 10)
4. Slide band clamps (do not tighten) over expanded ends of **Borla X-pipe**.
5. Referencing the page-2 drawing for orientation, slide expanded end of **Borla X-pipe** over **Borla S-pipes**. (See fig. 11)
6. Reinstall OE crossmember. (See fig. 12)



WARNING: Use extreme caution during installation. Torque all fasteners according to manufacturer's torque values and tightening sequence. **DO NOT** use air impact tools to tighten fasteners on Borla Performance Exhaust Systems. Use of such tools may result in bent flanges or gasket contact areas leading to exhaust leaks.

NOTE: When you first start your vehicle after the installation of your new Borla Performance Exhaust System, there may be some smoke and fumes coming from the system. This is a protective oil based coating used in the manufacturing of mandrel bent performance exhaust tubing. This is not a problem and will disappear within a very short period of time after the exhaust has reached normal operating temperatures.

Borla Performance Cat-Back™ Exhaust System Installation Cont'd

1. Slide band clamps (do not tighten) over L/H and R/H **Borla intermediate pipes**.
2. Referencing the drawing on page 2 for orientation, slide L/H and R/H **Borla intermediate pipes** over **Borla X-pipe**. (See fig. 13)
3. Insert intermediate pipe hangers into rubber isolators.
4. Slide band clamps (do not tighten) over L/H and R/H **Borla muffler assembly tailpipes**.
5. Referencing the page-2 drawing for orientation, fit the L/H and R/H **Borla muffler assemblies** to the **Borla intermediate pipes**. (See fig. 14)
6. Insert L/H and R/H muffler assembly hangers into OE rubber isolators.
7. Reconnect L/H and R/H tailpipe assembly rubber isolator brackets. Reconnect wire harness to valve actuator. (See fig. 15)
8. Check your exhaust system for proper clearance under the vehicle and also for tip alignment. Space **Borla rear muffler assemblies** by adjusting the **middle bracket**. (See fig. 16)
9. Once position has been determined to be correct, tighten clamp bolts and cross-muffler bracket to 33-35 ft. lb.
10. Before starting your vehicle, make sure to check all wires, hoses, brake lines, body parts and tires for safe clearance from the exhaust system.
11. Start vehicle and check for any leaks. If any leaks are found, determine cause and repair as necessary.

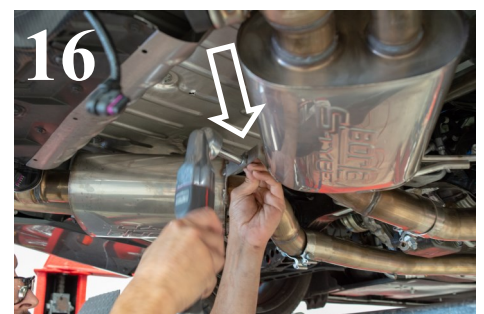
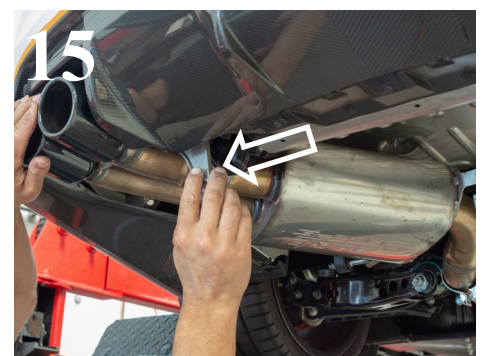

WARNING: Use extreme caution during installation. Torque all fasteners according to manufacturer's torque values and tightening sequence. **DO NOT** use air impact tools to tighten fasteners on Borla Performance Exhaust Systems. Use of such tools may result in bent flanges or gasket contact areas leading to exhaust leaks.

NOTE: When you first start your vehicle after the installation of your new Borla Performance Exhaust System, there may be some smoke and fumes coming from the system. This is a protective oil based coating used in the manufacturing of mandrel bent performance exhaust tubing. This is not a problem and will disappear within a very short period of time after the exhaust has reached normal operating temperatures.